

# REGIONAL SHOPPING CENTER-*NOW LEASING*

## 1015 N. 18<sup>TH</sup> ST. CENTERVILLE, IA

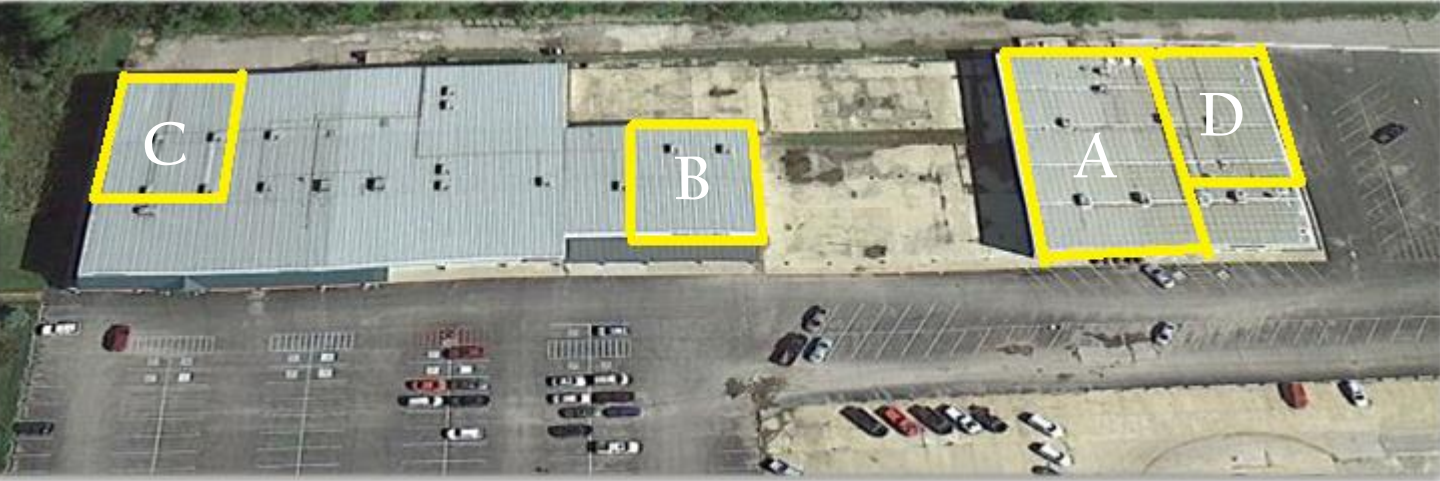

Lake Center Mall is 1/2 Mile North of the Intersection of State Highways 2 & 5



### Property Information:

#### (2) Retail Spaces Available

A: 9,450 SF- \$6.00/NNN

B: 4,000 SF- \$6.00/NNN

#### (2) Warehouse Spaces Available

C: 6,500 SF- \$1.00/NNN

D: 6,200 SF- \$1.00/NNN

Lighted Parking- 361 Spaces

Zoning- Commercial

Traffic Count- 12,750 VPD (2010)

**Tom Hudson** 515-453-5480  
TomHudson@IowaRealtyCommercial.com



# REGIONAL SHOPPING CENTER- NOW LEASING 1015 N. 18<sup>TH</sup> ST. CENTERVILLE, IA

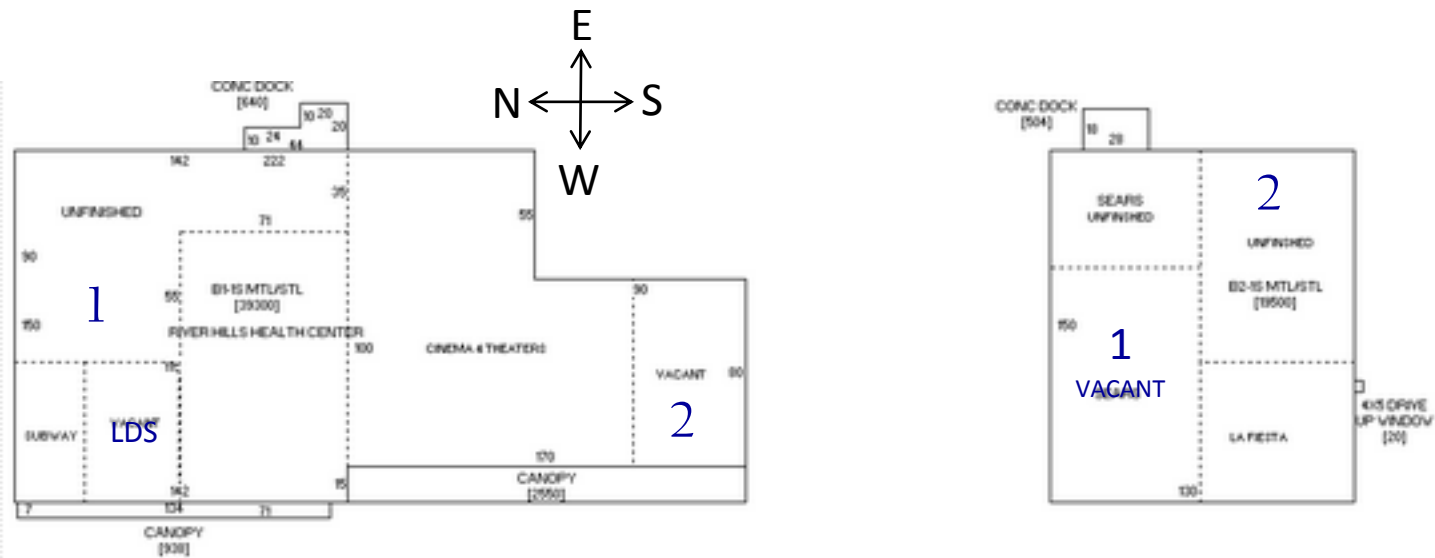

## Retail Spaces - \$6.00/SF NNN + CAM

- Vacancy 1- 9,450 SF (63'x150') Divisible!
- Vacancy 2- 4,000 SF (50'x80') Divisible!
- Term- 3 to 5 Years

## Warehouse/ Storage Spaces- \$1.00/SF NNN + CAM

- Unfinished 1- 6,500 SF (72'x90') Divisible!
- Unfinished 2- 6,200 SF (65'x95') Divisible!
- Term- 6 Mos. To 1 Year
- Clear Heights: 17'- 22'
- Fully Wet Sprinkler System
- Semi Docks in Place

2015 Operating Expenses- \$2.32/SF

**Tom Hudson** 515-453-5480  
TomHudson@IowaRealtyCommercial.com

**IowaRealty**  
**COMMERCIAL**